

Union Special

INDUSTRIAL SEWING EQUIPMENT

ADJUSTING INSTRUCTIONS

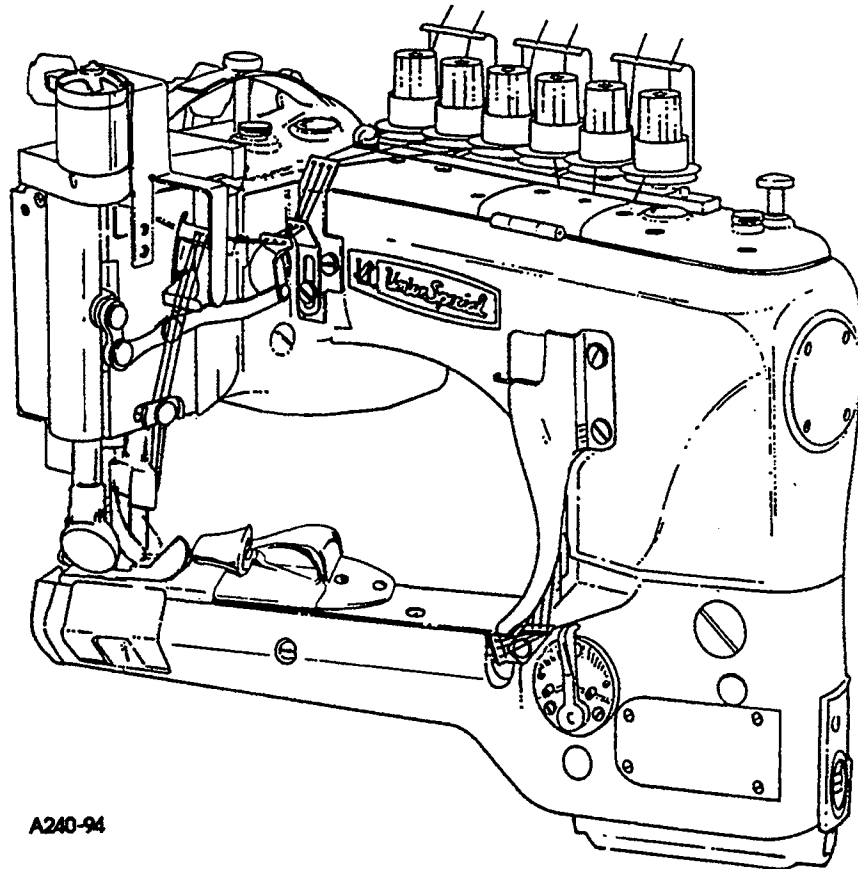

A240-94

Differential Feed,
High Speed
Feed-Off-The-Arm
Machines

MANUAL NO. IN9406

STYLES

35800DLW
35800DWW
35800DWWL

Manual No. IN9406 Adjusting Instruction for 35800 Series Machines

Fourth Edition Copyright 1994

By

Union Special Corporation Rights Reserved In All Countries

Printed in U.S.A. June 1994

PREFACE

This parts manual has been prepared to guide you while adjusting the 35800 Series machines. It can be used in conjunction with Union Special Parts Manual PT9407.

This manual explains in detail the proper setting for each of the components related to forming the stitch and completing the functions of the machine. Illustrations are used to show the adjustments and reference letters are used to point out specific items discussed.

Careful attention to the instructions for operating and adjusting these machines will enable you to maintain the superior performance and reliability designed and built into every Union Special machine.

Adjustments are presented in sequence so that a logical progression is accomplished. Some adjustments performed out of sequence may have an adverse effect on the function of the other related parts.

This manual has been comprised on the basis of available information. Changes in design and/or improvements may incorporate a slight modification of configuration in illustrations or part numbers.

On the following pages will be found illustrations and terminology used in describing the adjustments for the 35800 Series machines.

SAFETY RULES



General Operating Directions

The sewing machines described in this instruction manual are prohibited from being put into service until it has been ascertained that the sewing units, in which these sewing machines will be built-in have conformed with the EC Council Directives (89/392/EEC, Annex II B).

1. Before putting the machines described in this manual into service, carefully read the instructions. The starting of each machine is only permitted after taking notice of the instructions and by qualified operators.

IMPORTANT! Before putting the machine into service, also read the safety rules and instructions from the motor supplier.

2. Observe the national safety rules valid for your country.
3. Each machine is only allowed to be used as foreseen. The foreseen use of the particular machine is described in paragraph "STYLES OF MACHINES" of this instruction manual. Another use, going beyond the description, is not as foreseen.
4. All safety devices must be in position when the machine is ready for work or in operation. Operation of the machine without the appertaining safety devices is prohibited.
5. The following safety devices are components of the sewing machines: Sewing guard, needle lever eyelet guard, needle bar guard, needle break protection shield and handwheel-belt guard.
6. When gauge parts are exchanged (i.e. needle, presser foot, needle plate, feed dog and bobbin), during threading, when the operator leaves the workplace, during service work, the machine must be isolated from the main power by switching off the main switch or disconnecting the main plug. On mechanically operated clutch motors without a start inhibitor it is necessary to wait until the motor has stopped.

7. Wear safety glasses.
8. In case of machine conversions and changes all valid safety rules must be considered. Conversions and changes are made at your own risk.
9. Commissioning of the sewing head is prohibited until such time as the entire sewing unit is found to comply with EC regulations.
10. The warning hints in the instructions are marked with one of these two symbols:



Items require special attention



Danger of injury to operative or service staff

Be sure to observe and adhere to these indications and to the generally applicable regulations.

Special Operating Directions

11. For the following, the machine has to be disconnected from the power supply by turning off the main switch or by pulling out the main plug:
 - 11.1 For threading needle(s), looper, spreader etc.
 - 11.2 For replacing sewing parts such as needle, presser foot, throat plate, looper, spreader, feed dog, needle guard, folder, fabric guide etc.
 - 11.3 When leaving the workplace and when the workplace is unattended.
 - 11.4 For maintenance work.
 - 11.5 When using clutch motors without actuation lock, wait until the motor is stopped totally.

General Maintenance Directions

12. Maintenance, repair and conversion work (see item 8) must be done only by trained technicians or special skilled personnel under consideration of the instructions.
13. Any work on the electrical equipment must be done by an electrician or under direction and supervision of special skilled personnel.

Special Maintenance Directions

14. Work on parts and equipment under electrical tension is not permitted.
15. Before doing maintenance and repair work on the pneumatic equipment, the machine has to be disconnected from the compressed air supply. In case of existing residual air pressure after disconnecting from compressed air supply (e.g. pneumatic equipment with air tank), the pressure has to be removed by bleeding.

Exceptions are only allowed for adjusting work and function checks done by special skilled personnel.

Standards

17. The sewing machines described in this manual are built according to the following standards:

EN292-2 Safety of machinery-basic concepts, general principles for design.

IEC204-3-1/EN60204-3-1 Electrical equipment of industrial machines. Part 3: Particular requirements for sewing machines, units and systems.

CONTENTS

•IDENTIFICATION OF MACHINES	5
•STYLES OF MACHINES	5
•NEEDLES	7
•LUBRICATION	7
•THREADING	7
ADJUSTING INSTRUCTIONS	
•TORQUE REQUIREMENTS	7
•SYNCHRONIZING NEEDLE AND LOOPER MOTIONS	8
•TIGHTENING NEEDLE BAR HEAD	9
•ALIGNING NEEDLES IN THROAT PLATE SLOTS	9
•CENTERING THE CYLINDER	9
•SETTING THE LOOPER	9
•SETTING THE LOOPER (CONT.)	10
•SETTING HEIGHT OF NEEDLE BAR	10
•SETTING THE FEED DOGS	10
•CHANGING STITCH LENGTH	10
•CHANGING STITCH LENGTH (CONT.)	11
•SETTING REAR NEEDLE GUARD	11
•PRESSER FOOT AND PRESSER BAR ADJUSTMENT	11
•UPPER FEED ROLLER ADJUSTMENT	12
•THREAD TENSION AND RELEASE	13
•DIFFERENTIAL CONTROL	13
•SETTING NEEDLE THREAD TAKE-UP AND FRAME EYELET	13
•LOOPER THREAD TAKE-UP ADJUSTMENT	13
•FOLDER ADJUSTMENT	14
•AIR BLOWER TUBE ADJUSTMENT	14
•NOTES	15

IDENTIFICATION OF MACHINES

Each UNION SPECIAL machine is identified by a Style number, which is stamped into the style plate affixed to the middle of the machine under the tension assembly. The serial number is stamped in the casting at the right rear base of the machine.

STYLES OF MACHINES

High Speed, Feed-Off-The-Arm High Throw Machines, Two or Three Needle, Left Needle In Front, Operator Controlled Differential Feed. Light Weight Presser Bar Mechanism, Adjustable Looper Avoid, Space in Front of Needles 8" (203.2mm), Single Disc Looper Thread Take-up, Automatic Enclosed Type Oiling System and Filter Type Oil Pump, Visual Sight Oil Action and Supply Gauges, .558" (9/16", 14mm) wide feed roller.

- 35800DLW **DOUBLE LAP SEAM.** Three needle, low capacity, differential feed, upper driven roller feed (wide roller). -Typical application- For in and out seams on medium weight denim garments. Seam specifications 401 LSc-3. Standard gauge number 9 (9/64", 3.6mm). Maximum recommended speed 4500 R.P.M.. Recommended needle 130 GS, size 125/049. .040 step parts.
- 35800DWW **DOUBLE LAP SEAM.** Two and Three needle, high capacity, differential feed, high lift feed eccentric with upper driven roller feed (wide roller). Feeds have higher teeth on front of feeds. -Typical application- For use on heavy weight denim garments. Seam specifications 401 LSc-2 or 401 LSc-3. Standard gauge numbers 8 (1/8", 3.2mm), 9 (9/64", 3.6mm) and 18 (9/32", 7.2mm) NOTE: 18 gauge is ONLY available with two needles. Maximum recommended speed 4500 R.P.M.. Recommended needle 130 GS, size 140/054. .094 step parts.
- 35800DWWL **DOUBLE LAP SEAM.** *Same as the 35800DWW without the folder.* Two and Three needle, high capacity, differential feed, high lift feed eccentric with upper driven roller feed (wide roller). Feeds have higher teeth on front of feeds. -Typical application- For use on heavy weight denim garments. Seam specifications 401 LSc-2 or 401 LSc-3. Standard gauge numbers 8 (1/8", 3.2mm), 9 (9/64", 3.6mm) and 18 (9/32", 7.2mm) NOTE: 18 gauge is ONLY available with two needles. Maximum recommended speed 4500 R.P.M.. Recommended needle 130 GS, size 140/054. .094 step parts.

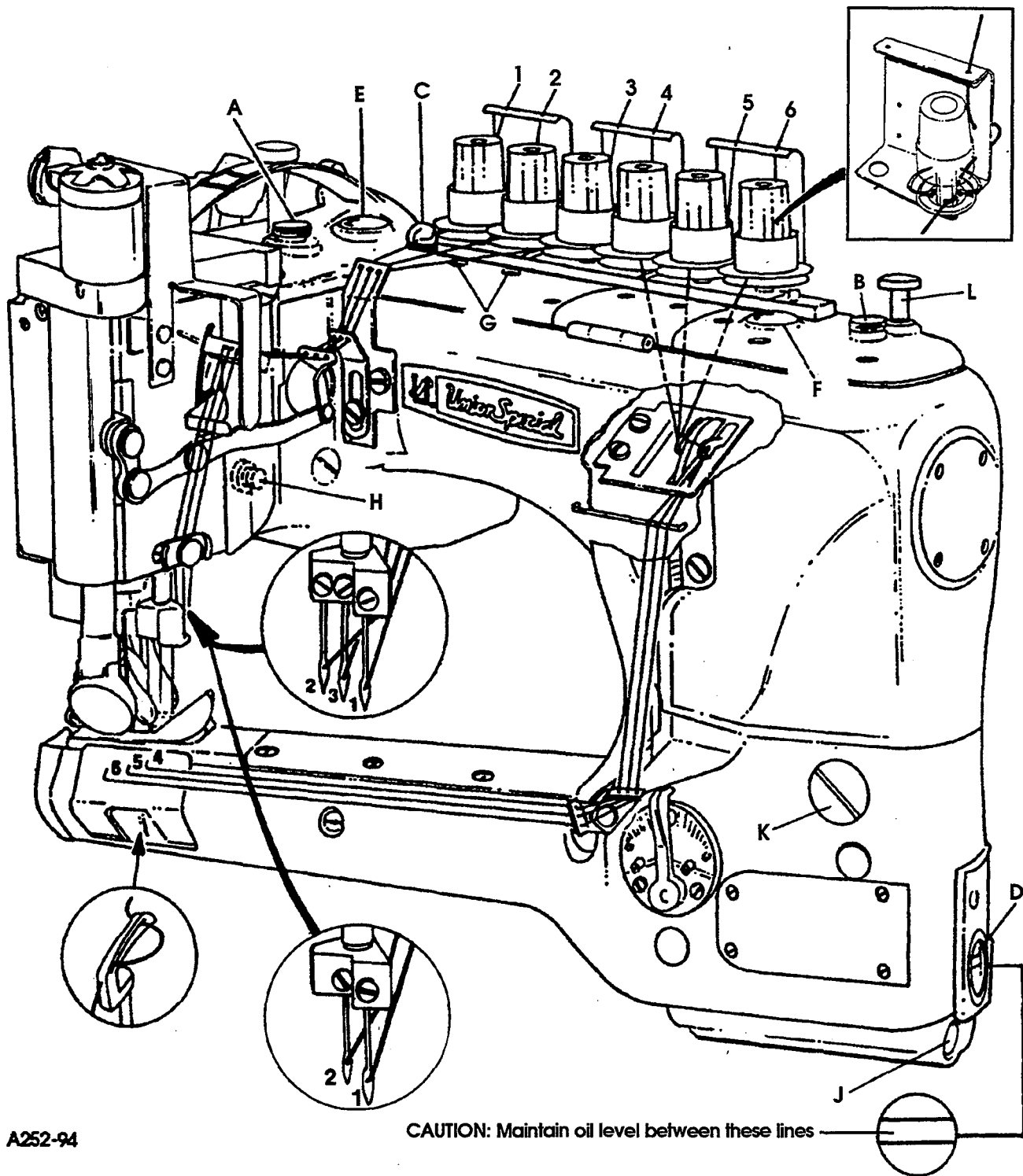

A252-94

CAUTION: Maintain oil level between these lines

- | | | | |
|---|---------------|-----|----------------------|
| A | Oil Cap | G | Plug Screw |
| B | Oil Cap | H | Plug Screw |
| C | Sight Gauge | J | Plug Screw |
| D | Sight Gauge | K | Plug Screw |
| E | Lucite Window | L | Looper Position Knob |
| F | Lucite Window | 1-6 | Thread Tension Knobs |

NOTE: On Styles 35800DWW18 & 35800DWWL18 center needle & looper is not used

FIG. 1

Needle Type	Description	Sizes Available
130GS	Short double groove, struck groove, ball eye, spotted, government point, chromium plated.	080/032, 090/036, 100/040, 110/044, 125/049, 140/054, 150/060

Table I

NEEDLES

Selection of proper needle size is determined by size of thread used. Thread should pass freely through the needle eye in order to produce a good stitch formation.

Each needle has both a type and size number. The type number denotes the kind of shank, point, length, groove, finish and other details. The size number, stamped on the needle shank, denotes largest diameter of blade, measured midway between shank and eye. Collectively, type and size number represent the complete symbol which is given on the label of all needles packaged and sold by UNION SPECIAL. See "STYLE OF MACHINES" for the standard recommended needle type & size for your machine.

To have needle orders promptly and accurately filled, an empty package, a sample needle, or the type and size number should be forwarded. Use the description on the label. A complete order would read: "1000 Needles, Type 130GS, Size 110/044".

LUBRICATION

The oil has been drained from the machine before shipping and the reservoirs must be filled before beginning to operate. Use a straight mineral oil with a Saybolt viscosity of 90 to 125 seconds at 100° Fahrenheit. Union Special Part No. 28604R.

Oil is filled at oil caps (A & B, Fig. 1). The level is checked at sight gauges (C) and (D). Maintain the oil level between the red lines of the gauges.

The machine is equipped with a continuous running rotary driven oil pump. The action of the oil can be observed through Lucite windows (E) and (F) in the front and back top covers.

When starting a new machine, filling the reservoirs or when beginning to operate a machine that has been idle for some time, it may be necessary to prime the pump. To do this, remove the two plug screws (G). Apply oil to these holes and operate machine until bubbling can be observed at the windows. Replace screws (G).

CAUTION: If oil does not bubble when machine is running, the circulating pump is inoperative.

Oil may be drained from the machine at two places, plug screw (J) located in the bottom of the cylinder and plug screw (H) at the back of the main frame below the handwheel.

THREADING

A convenient means for threading the looper has been provided. When loopers are at the left end of their travel, press the knob (L, Fig. 1) and loopers will back out of position, leaving them easily accessible. Thread the machine as illustrated in Fig. 1. After threading, push loopers back into position.

ADJUSTING INSTRUCTIONS

NOTE: Instructions stating direction of location, such as right, left, front or rear of machine, are given relative to operator's position at the machine. The handwheel rotates counterclockwise, in operating direction; when viewed from the right end of machine.

TORQUE REQUIREMENTS

Torque specifications given in this catalog are measured in inch-pounds or Newtonmeters. All straps and eccentrics must be tightened to 19-21 in. lbs. (2.1-2.3Nm) unless otherwise noted. All nuts, bolts, screws, etc., without torque specifications must be secured as tightly as possible, unless otherwise noted. Special torque specifications for connecting rods, links, screws etc., are shown on the parts illustrations.

SYNCHRONIZING NEEDLE AND LOOPER MOTIONS

NOTE: Needle and looper mechanisms are carefully synchronized with precision gauges before leaving the factory to insure the best possible sewing conditions.

Should it become necessary to disassemble the main shaft or replace components of the needle or looper drive mechanisms, re-synchronization of the machine will be required to facilitate proper sewing adjustments. This is accomplished by means of an adjustable split coupling located beneath the rear top cover, connecting the crankshaft to the main shaft, which in turn drives the looper mechanism.

To synchronize the machine, remove the needles, presser foot, throat plate, feed dogs and upper feed roller mechanism. Rotate handwheel in the operating direction until the needle bar is at the bottom of its stroke and just begins its upward travel. Loosen screw (A, Fig. 2) and remove the looper for the left hand needle from the looper holder. Insert a straight steel rod (B) 5/32" (3.9mm) or 11/64" (4.3mm) diameter by 2-1/2" (63.5mm) long into looper holder and retighten screw (A). It may be necessary to reposition the looper holder so that the rod (B) will be in a vertical position when at its farthest travel to the right. Rotate the handwheel until the rod is at extreme left, reinstall the throat plate. Turn the handwheel in the operating direction, with needle bar rising until rod (B) comes in contact with the edge of the throat plate. At this point, clamp Union Special timing gauge No. 21225H (C) around the needle bar (D), flush against the underside of the machine casting (E). Rotate handwheel in the opposite direction until either the gauge contacts the machine casting on the up stroke of the needle bar or the rod contacts the edge of the throat plate. Maximum allowable clearance between gauge and casting or rod and throat plate is .005" (0.1mm)

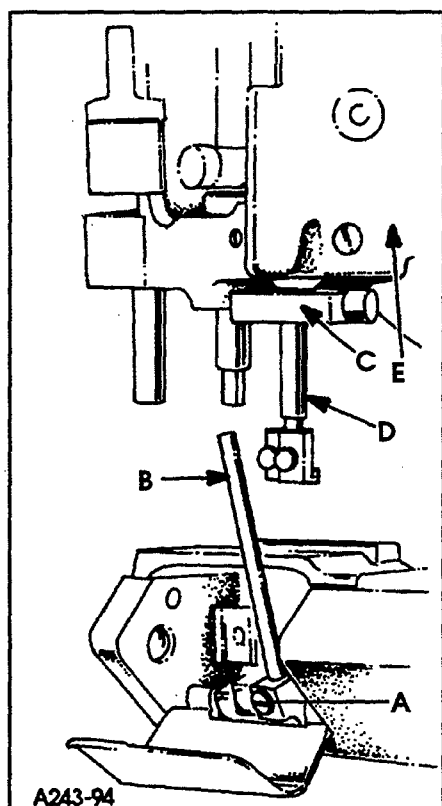

FIG. 2

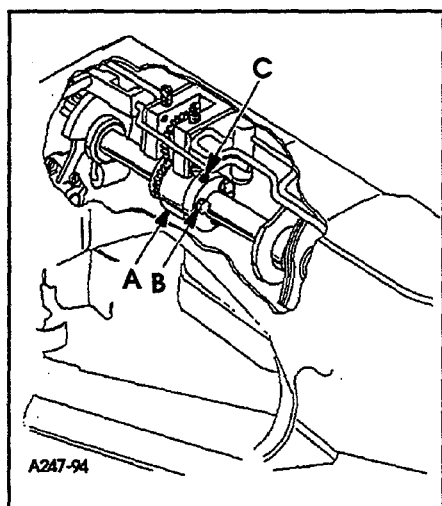

FIG. 3

If machine is not synchronized the following applies:

Both ends of the adjustable split coupling are secured to the crankshaft and main shaft by spot screws and set screws. On the main shaft end of the coupling (A, Fig. 3) three screws (B) thread horizontally through the coupling. The holes in the main shaft end of the coupling are larger than the diameter of the screws, permitting several degrees of rotation in either direction to properly synchronize the needle and looper. Loosen the three horizontal clamp screws (B, Fig. 3). With rod (B, Fig. 2) at its farthest position to the left, snug the uppermost horizontal clamp screw enough to hold coupling (A, Fig. 3) in position. If the handwheel is turned in reverse of operating direction and gauge (C, Fig. 2) on needle bar (D) contacts the machine casting (E) before rod (B) contacts the edge of the throat plate, loosen horizontal clamp screw (B, Fig. 3) which was snug, while holding the coupling in place with an Allen wrench in set screw (C). Rotate the handwheel slightly in reverse of operating direction, snug the uppermost horizontal clamp screw (B), recheck synchronization. If the handwheel is turned in reverse of operating direction and the rod contacts the edge of the throat plate before the clamp gauge contacts the machine casting, adjust as before, except turn the handwheel slightly in the operating direction. Use shim stock to insure no more than .005" (0.1mm) exists between gauge and casting or between rod and throat plate, in both the operating and reverse directions of the handwheel. When this setting has been made, tighten the three horizontal clamp screws (B, Fig. 3) securely, and recheck both clearance points with .005" (0.1mm) shim gauge to assure no slippage occurred while tightening the screws.

TIGHTENING NEEDLE BAR HEAD

When replacement of the needle bar head is necessary, torque to 17 in. lbs. (1.92Nm) or use torque rod No. 21227AR that has been supplied with the machine for the purpose of eliminating the possibility of distorting the needle bar due to overtightening. Insert the torque rod in the hole at the upper end of the needle bar, while holding the needle bar head with a suitable tool, turn the needle bar with the torque rod onto the needle bar head. When the rod starts to bend, the needle bar head has been threaded into the needle bar the proper distance.

ALIGNING NEEDLES IN THROAT PLATE SLOTS

Insert a new set of needles, type and size specified, with screw (B, Fig. 4) slightly loosened, lower needle bar (A) and turn needle head as required until the needles are centered in the throat plate needle hole slots. Tighten screw (B).

NOTE: If the needles can not be aligned in the throat plate slots, the lower cylinder must be moved as stated below.

CENTERING THE CYLINDER

Remove the top front cover and gasket from the main frame. Loosen cylinder holding screws (A, Fig. 5). Turn eccentric screw (B) clockwise or counterclockwise to move the cylinder so the needles are centered in the needle holes. Tighten screws (A) and recheck settings. Various components may have to be removed from the machine so cylinder holding screws (A) can be accessed.

NOTE: The cylinder may not move freely when the eccentric is turned because the joint sealant compound has set.

SETTING THE LOOPER

Insert a new set of needles, type and size specified. Always adjust the looper (A, Fig. 6) for the left needle first. Set the looper so that the distance from the center of the needle (B) to the point of the looper (A) is $9/64$ " (3.6mm) when the looper is at its farthest position to the left. Looper gauge (C) No. 21225-9/64 can be used advantageously in making this adjustment. If adjustment is required, loosen screw (A, Fig. 7) in looper holder, permitting movement in either direction to attain the $9/64$ " (3.6mm) dimension as shown in Fig. 6. Retighten screw (A, Fig. 7). Repeat for other needles and loopers.

Rotate handwheel in operating direction to assure that the looper point passes to the rear of the needle as close as possible without contacting. This adjustment can be made by loosening screw (A, Fig. 7) in looper holder. Looper holder can be moved front to back to attain looper to needle setting. Always check the $9/64$ " (3.6mm) looper gauge setting after setting the looper to the back of the needle, and conversely, always check the setting of the looper to the back of the needle after setting the $9/64$ " (3.6mm) looper gauge.

The looper avoid motion is adjustable and should be set so that the descending needle points contact the lower 1/3 of the back of the looper blade. (See Fig. 7).

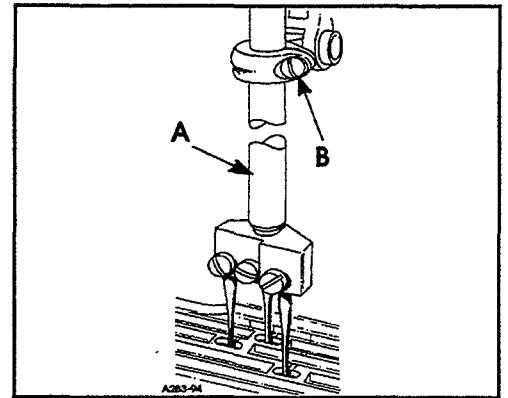

FIG. 4

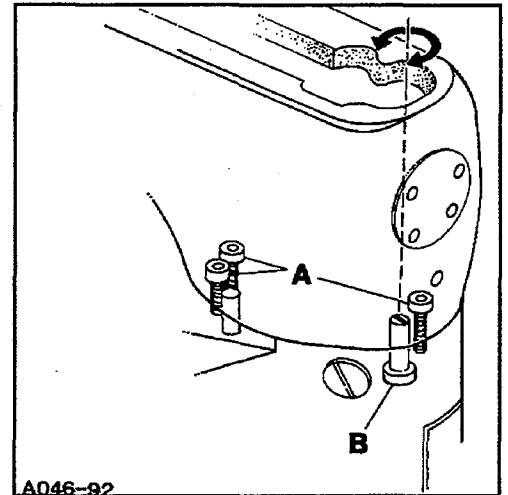

FIG. 5

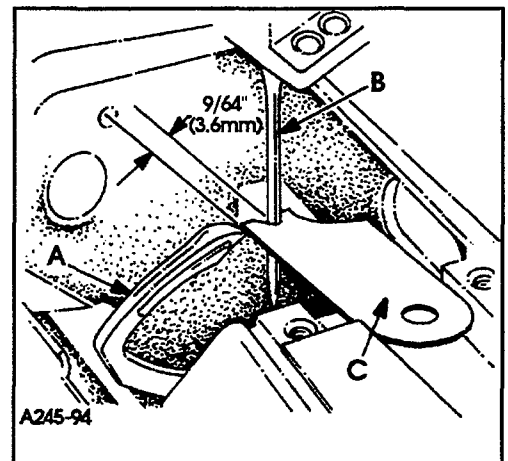

FIG. 6

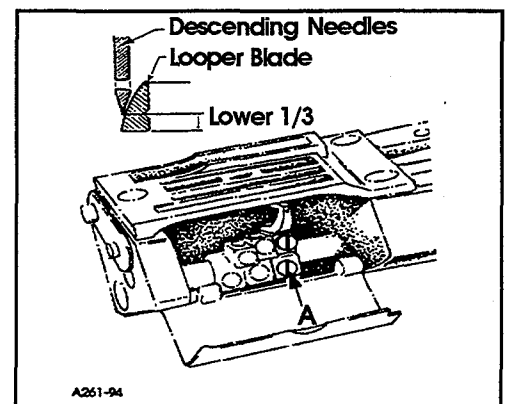

FIG. 7

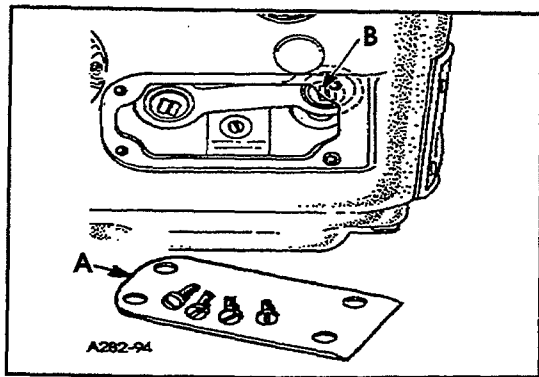

FIG. 8

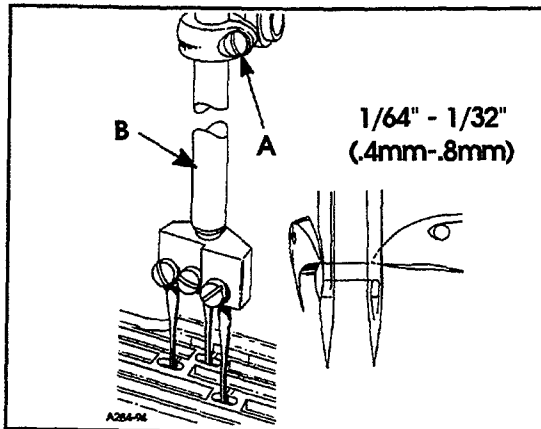

FIG. 9

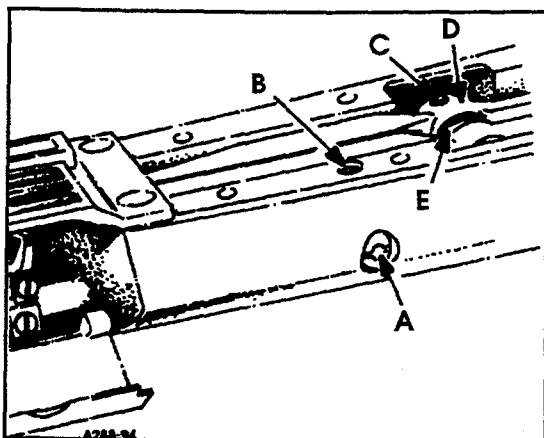

FIG. 10

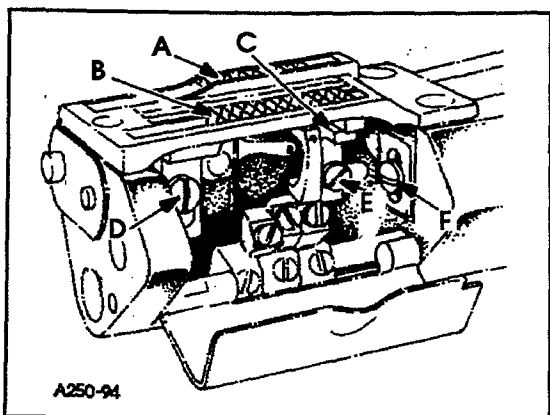

FIG. 11

SETTING THE LOOPER (CONT.)

If more or less looper avoid motion is required, remove the cylinder side cover (A, Fig. 8) located at the lower front left side. Use a screwdriver to loosen looper avoid link ball joint (B, Fig. 8). Moving ball joint down in the lever slot increases the amount of looper avoid motion, moving it up acts the reverse. Retighten ball joint securely.

NOTE: Whenever looper avoid is changed, looper clearance to needle must also be reset.

SETTING HEIGHT OF NEEDLE BAR

The height of the needle bar is correct when the top of the needle eye is 1/64" to 1/32" (0.4mm - 0.8mm) below the underside of the looper, with the looper point even with the right side of the needle. To make adjustment loosen screw (A, Fig. 9) and move needle bar (B) as required to attain dimension.

NOTE: Care must be taken not to disturb the alignment of the needles when moving the needle bar either up or down.

SETTING THE FEED DOGS

Before assembling the main and differential feed dogs, set the feed bar eccentric pin (A, Fig. 10) located in the left side near center of cylinder, so that the slot in the head is in a horizontal position. This assures a neutral position of eccentricity for the purpose of raising or lowering the height of the main and differential feed bars simultaneously. The feed bar pin is retained in position by set screw (B). Assemble differential feed dog (A, Fig. 11), main feed dog (B) and throat plate. Both the main and differential feed dogs can be individually adjusted to height. Main feed dog (B) at its highest position, should be set to project above the throat plate, slightly more than the depth of its teeth on Style 35800DLW and slightly more than the depth of its lower teeth on Styles 35800DWW, DWL. If adjustment is necessary loosen screw (D) and move feed dog (B) up or down to attain correct setting. Feed dog support (C) should support front of feed dog. If adjustment is necessary loosen screw (E) in feed dog support (C) and move as required. Retighten screw (E). The differential feed dog (A) may then be leveled with main feed dog (B). If adjustment is necessary loosen screw (F) and move feed dog up or down as required. Retighten screw (F).

NOTE: Should the main feed dog require repositioning due to contact with the throat plate in its forward or rearward travel, loosen set screw (C, Fig. 10) in main feed bar driving link (D), rotate main feed bar eccentric driving stud (E) as required. Driving stud (E) has a thin hexagon head with cutouts on two of the flats allowing movement by tapping with a sharp pointed tool, when wrench 21388AZ is not available. Whenever the main feed bar eccentric driving stud position has been changed, recheck rear needle guard setting, adjustment may be required. Retighten set screw (C). Position main feed dog support (C, Fig. 11) flush against bottom of main feed dog (B), tighten support screw (D) securely.

CHANGING STITCH LENGTH

When change in stitch length is required, remove large plug screw (A, Fig. 12). Loosen feed rocker driving link screw (B) in lever (C). Moving the feed rocker driving link up in the lever slot lengthens the stitch, moving it down, acts the reverse. Retighten link screw (B) securely and replace plug screw (A).

CHANGING STITCH LENGTH (CONT.)

NOTE: If plug screw (A) is replaced with a new plug screw, it should be sealed with a silicone seal. Any stitch length change, requires resetting the needle guard.

SETTING REAR NEEDLE GUARD

Set the rear needle guard (A, Fig. 13) horizontally so that it barely contacts needles (B) when at its extreme forward position. If adjustment is necessary loosen screw (E) and move guard front to back as required. It should be set vertically as low as possible, yet have its guarding surface in contact with the needles until the points of the loopers (C), moving to the right, are even with the right side of the needles. If adjustment is necessary loosen screw (F) and move guard and holder up or down as required.

CAUTION: If stitch length is changed, needle guard must be reset.

NOTE: When installing needle it should be parallel with the eye in line of feed. If adjustment is necessary, loosen screw (N, Fig. 15) in needle head and rotate needle to attain adjustment (D, Fig. 13).

PRESSER FOOT AND PRESSER BAR ADJUSTMENT

Remove presser bar leaf spring (B, Fig. 14) and nut (A). Loosen screw (A, Fig. 15) on presser bar guide (B). Loosen screws (C) in upper collar and screws (D) in needle lever thread pull-off lever. Slide presser bar upward high enough to slip on presser foot yoke (E) with foot attached and tighten screw (F) on flat of presser bar. Position foot so that the needle holes in the foot line up with the holes in the throat plate. Tighten screw (A).

Presser foot guide plates should be set so that entire presser foot and bar assembly has free movement up and down with no left to right movement.

With foot properly aligned on throat plate and presser bar guide (B, Fig. 15) securely fastened to presser bar, adjust both guide plates (G) to attain above setting. Tighten four screws (H).

Reinstall presser bar leaf springs (B, Fig. 14) and nut (A), with presser foot resting on throat plate.

Set upper collar (K) to contact casting, so the bottom of the needle head and the top of the presser foot do not touch, at the bottom of the needle stroke when lifting foot. Tighten screws (C).

The presser foot should be adjusted to be $1/8"$ (3.17mm) above the throat plate before the feed roller mechanism begins to rise. Loosen screw (A) in presser bar lifter and guide (B), raise or lower guide as required to attain the specified point at which the feed roller begins to rise. Retighten screw (A) and maintain needle settings.

NOTE: There should be a minimum $1/32"$ (0.8mm) clearance between screw (M, Fig. 15) and the bottom of the slot in link (J).

Regulate the pressure on the presser foot same as the upper feed roller by turning the presser spring regulating nut (A, Fig. 14) located on top of leaf type spring (B) at the rear of machine.

To remove just the presser foot, remove screws (L, Fig. 15) and replace foot, retighten screws (L).

Needle lever thread pull-off (P) should be set $1/8"$ (3.17mm) above bottom of slot in cover (Q) when presser foot is resting on throat plate.

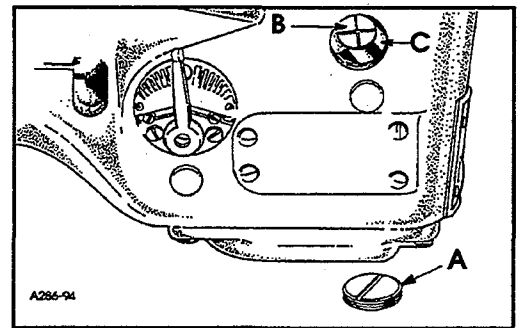

FIG. 12

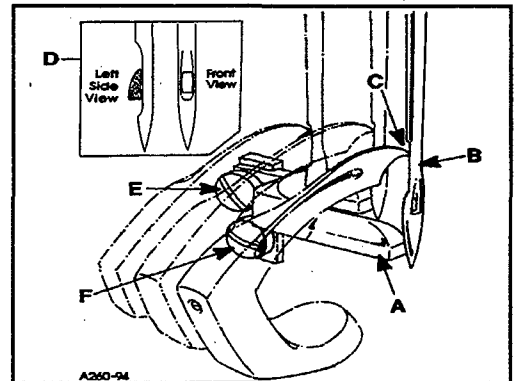

FIG. 13

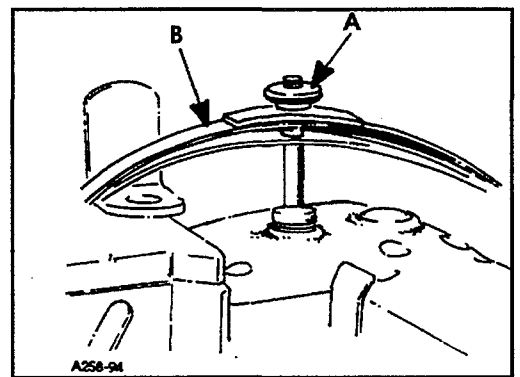

FIG. 14

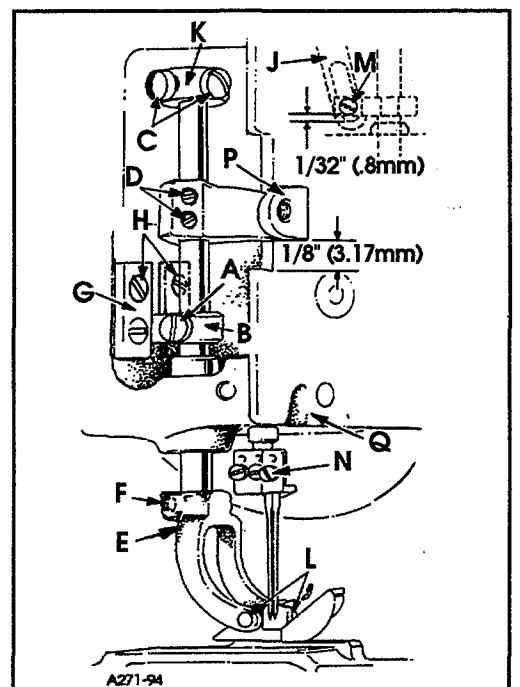

FIG. 15

UPPER FEED ROLLER ADJUSTMENT

When upper feed roller mechanism has been removed or replaced, .003" (0.10mm) minimum to .005" (0.13mm) maximum clearance should be maintained between roller and throat plate. With presser bar connection (A, Fig. 16) properly positioned and secured on roller presser bar with spot screw (B) and set screw (C), turn screw (D) clockwise until a .003" (0.10mm) to .005" (0.13mm) shim can be inserted between roller and throat plate. Remove shim.

Adjusting Guiding System for Roller:

Puller bar guide plate should be set so that entire roller mechanism has free movement up and down with no left to right movement. With roller properly aligned, the edge of roller should be parallel with feed slots in throat plate and presser bar guide (E) securely fastened to puller shaft. Adjust both guide plates (F) to attain proper setting, tighten four screws (G).

Assembly of Roller to Roller Yoke:

Assemble driven gear (A, Fig. 17) through feed roller frame (B). Place woodruff key (C) into slot of feed roller shaft (D). Slide driven gear (E) on to shaft (D), make sure key (C) goes into slot in gear (E). While holding feed roller frame (B) with steel roller (F) between the two frame lobes, slide feed roller shaft (D) and assembled components through frame. Make sure that shoulder of roller (F) is to the right. Align screw (G) (first in operating direction on roller) on the flat of shaft (E). At the same time thrust shoulder of shaft (D) against face of gear (E), make sure left edge of roller is against right (inside) face of left lobe. Secure screw (G) on flat of shaft (D) and tighten screw (H).

Setting Pressure for Feed Roller:

Regulate the pressure on the feed roller so that it exerts only enough pressure on the fabric to feed the work uniformly. Turning roller presser spring regulator (H, Fig. 16) clockwise to increase or counterclockwise to decrease the pressure.

Setting Travel of Feed Roller:

After feed dog has been set to proper stitch length, roller should be set to maintain the same. To adjust the amount of travel of the roller, loosen nut (J, Fig. 16) move ball joint assembly (K) up in clutch driving segment lever (L) to acquire more feed action, moving down acts the reverse. Retighten nut (J).

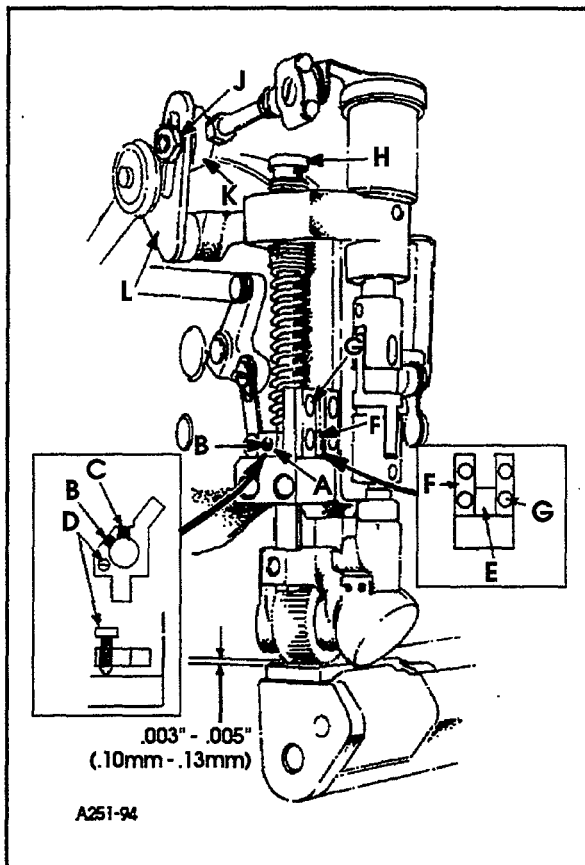

FIG. 16

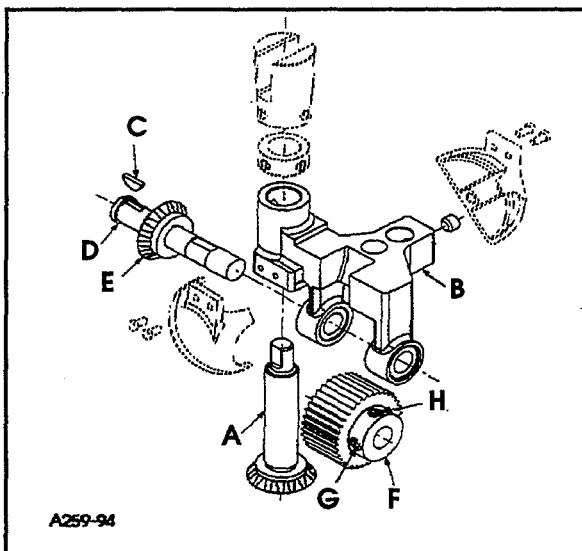

FIG. 17

THREAD TENSION AND RELEASE

The thread tension release is set correctly when it begins to function at the point when the upper feed roller begins to rise. When adjustment is necessary, loosen screw (B, Fig. 18) in lifter lever (C). Facing the tension release shaft (A) from the right end of the machine, insert screwdriver in slot in shaft (A). Turn the screwdriver clockwise to raise pins (D) or counterclockwise to lower pins. Retighten screw (B).

DIFFERENTIAL CONTROL

The amount of differential is controlled by lever (A, Fig. 19). The adjusting plate is numbered from 1 to 9. When the lever is set from numbers 1 to 4 reverse differential or stretching occurs. The numbers from 4 to 5 produce equal feed stitching while numbers 5 to 9 produce a gathering stitch. Screws (B) can be set to limit the movement of lever (A) or lock lever in one position. If top ply is coming out long, move lever toward operator, if top ply is short, move lever away from operator, as required.

SETTING NEEDLE THREAD TAKE-UP AND FRAME EYELET

With the needle bar at the top of its stroke set the adjustable frame needle thread eyelet (A, Fig. 20) in the lower mounting hole of eyelet (B), so the needle thread from eyelet (A) to the needle lever thread eyelet (C) will be in a straight line. If adjustment of eyelet (A) is necessary loosen screw (K) and move eyelet up or down as required. Retighten screw (K).

With the needle bar at the bottom of its stroke, the needle thread take-up (D) should be set so that it is $1/16"$ (1.5mm) above the edge of the needle lever thread eyelet (C) (See Inset). If adjustment is necessary loosen screw (H) and adjust lever (D) as required to attain $1/16"$. Tighten screw (H). With the needle at the bottom of its stroke, there should be $1/16"$ (1.6mm) between eyelets (A and G). If adjustment is necessary loosen screw (J) and move eyelet (G) as required to attain $1/16"$. Tighten screw (G).

LOOPER THREAD TAKE-UP ADJUSTMENT

With the machine rotating in operating direction the looper thread take-up is in time when the first screw coming into view (A, Fig. 21) is in line with the spot screw (B) on the main shaft in the pulley. NOTE: screw (A) is accessible through the hole in the take-up. With this setting correct, the looper thread should cast-off of the take-up (C) when the needles are safely in the triangle. If adjustment is necessary loosen two screws (A) in take-up (C) position screws in line with spot screw (B). Tighten screws (A).

NOTE: Make sure take-up cam is centered left to right in cast-off slot.

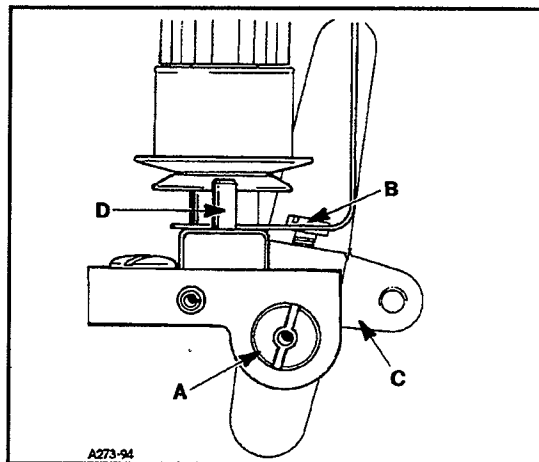

FIG. 18

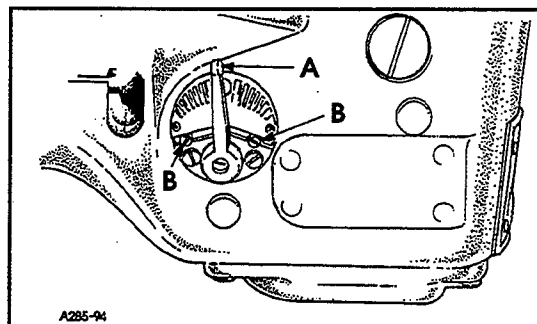

FIG. 19

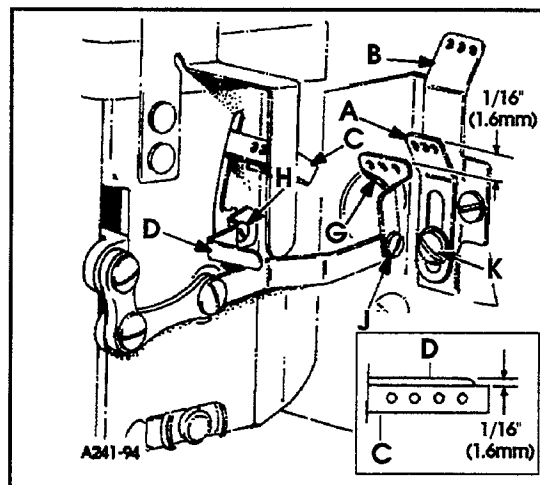

FIG. 20

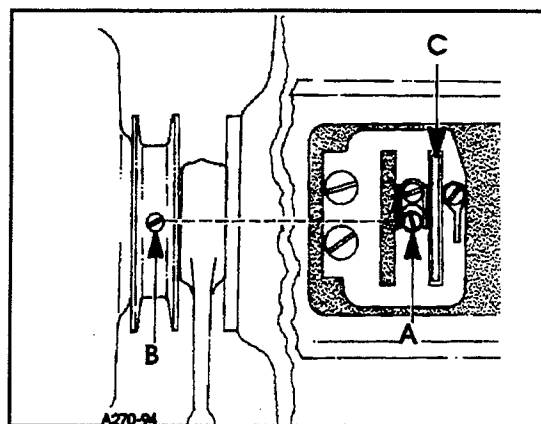

FIG. 21

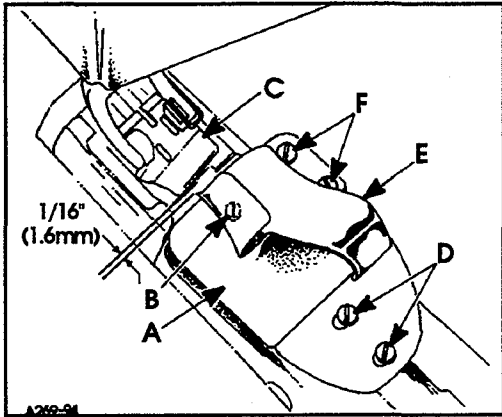

FIG. 22

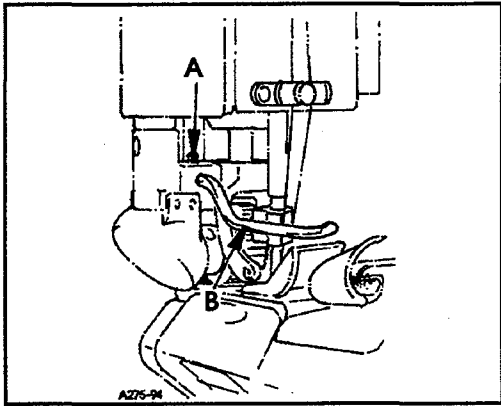

FIG. 23

FOLDER ADJUSTMENT

Slide folder (A, Fig. 22) on arm, until it is stopped by stop screw (B). The folder should be as close to the front of presser foot (C) as possible, making sure to avoid the presser foot contacting the folder when sewing across seams. Margins should be approximately 1/16" (1.6mm). If adjustment is necessary loosen screws (D) to move entire folder left to right or front to back as required. If just adjustment of upper scroll (E) is needed loosen screws (F) and position scroll to attain proper seam margin.

AIR BLOWER TUBE ADJUSTMENT

The air blower tube should be set left to right so it is parallel with the throat plate. It should be set front to back so when feeding over a cross seam the presser foot does not contact the tube. If adjustment is necessary, loosen screw (A, Fig. 23) and position air blower tube (B) as required. Retighten screw (A).

NOTES



A series of horizontal lines spanning the width of the page, providing a template for handwritten notes. There are 20 lines in total, starting from the top margin and ending near the bottom margin.



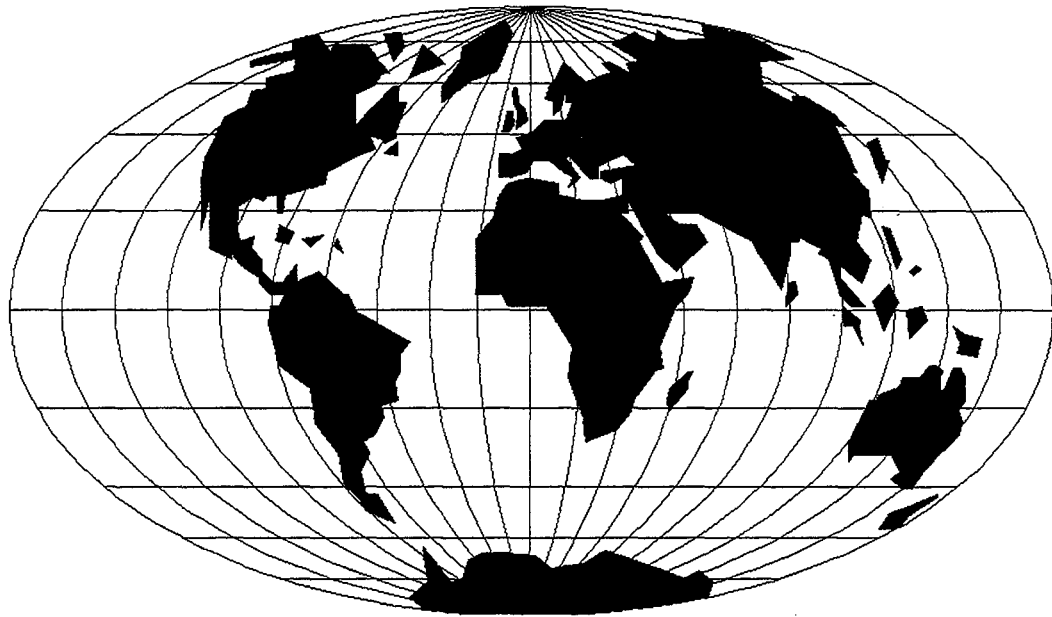

WORLDWIDE SALES AND SERVICE

Union Special Corporation maintains sales and service facilities throughout the world. These offices will aid you in the selection of the right sewing equipment for your particular operation. Union Special Corporation representatives and service technicians are factory trained and are able to serve your needs promptly and efficiently. Whatever your location, there is a qualified representative to serve you.

Corporate Offices:

One Union Special Plaza
Huntley, IL 60142
(708) 669-5101

Union Special GmbH
Raiffeisenstrasse 3
D-71696 Möglingen, Germany
Tel. 07141-2470

Brussels, Belgium
Commerce, CA
Leicester, England
Lille, France
Miami, FL
Möglingen, Germany
Huntley, IL
Milan, Italy
Osaka, Japan
Hong Kong
Charlotte, N.C.
Montreal, Quebec
El Paso, TX
Mission, TX

Other Representatives throughout all parts of the world.



Union Special
INDUSTRIAL SEWING EQUIPMENT